

Three channel LED DMX driver

▶ FEATURES

- R.G.B. Color (Three channels) intensity can be adjusted independently.
- Output capability 4.0A per channel at 25°C.
- Total output current 12A max
- Over current protection 4.0A per channel
- DMX address setting by external DMX address editor (DAE-02)
- DMX control mode manual mode and auto mode are available
- synchronize up to 30 units series with built-in program



▶ SPECIFICATION

OUTPUT POWER	144W/288W(12/24V) MAX
INPUT INTERFACE	1 x 2pin Green Terminals (DC 12-24V) 1 x 3pin Green Terminals (DMX IN)
OUTPUT INTERFACE	1 x 2pin Green Terminals (DC 12-24V) 1 x 3pin Green Terminals (DMX OUT) 1 x 6pin Green Terminals (V+ R- V+ G- V+ B-)
SIGNAL	DMX512(1990)
HOUSING	Sheet metal black powder finishing
INGRESS PROTECTION RATING	IP20
STORATION TEMPERATURE	-30°C -60°C
DIMENSION	L81XW73XH29mm
WEIGHT	180g

▶ PHYSICAL DIMENSIONS:

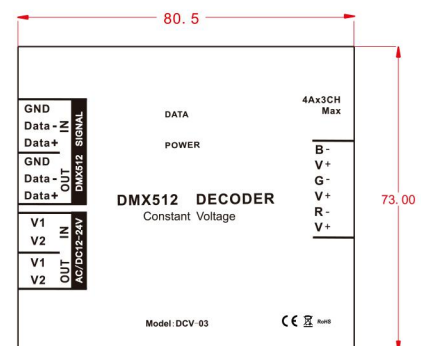

DMX512 Decoder

Item Code: 88609
Model No.: WP-DCV-03

DMX512 (1)

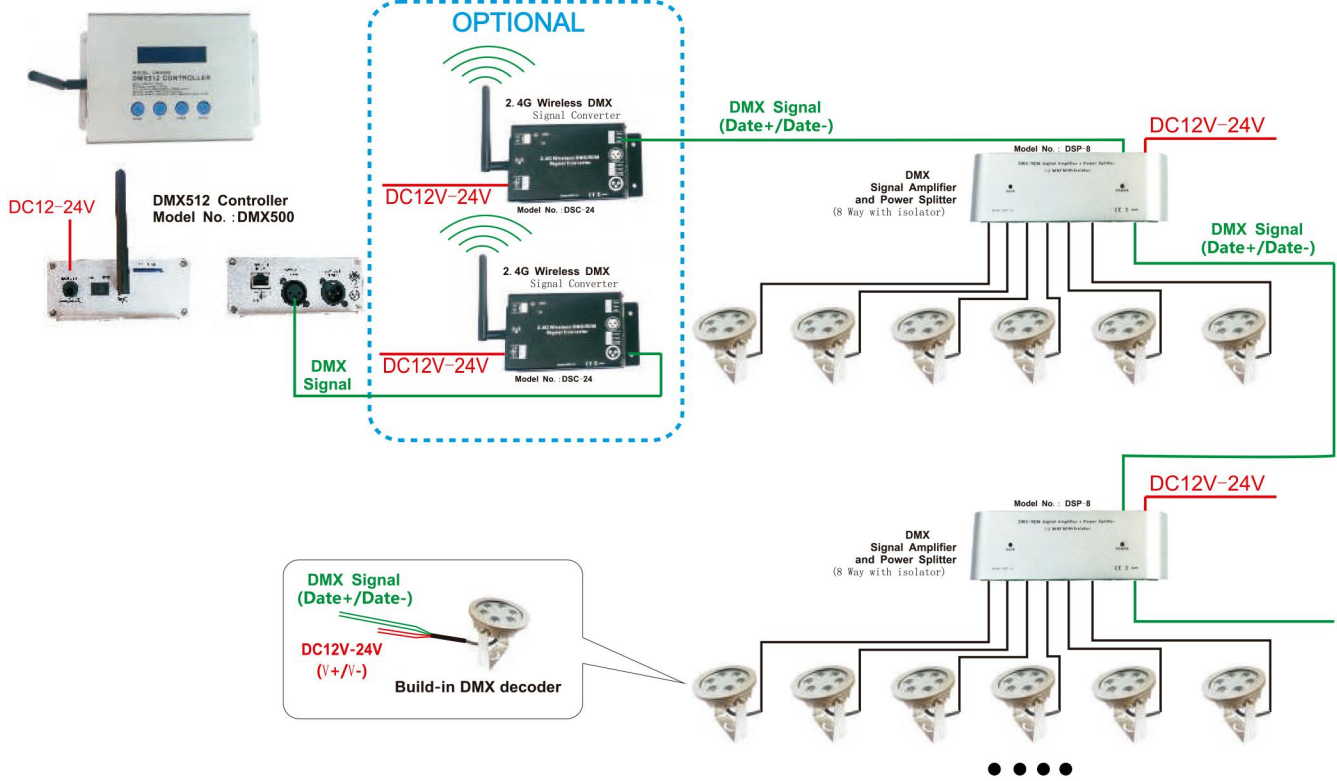

External (2)

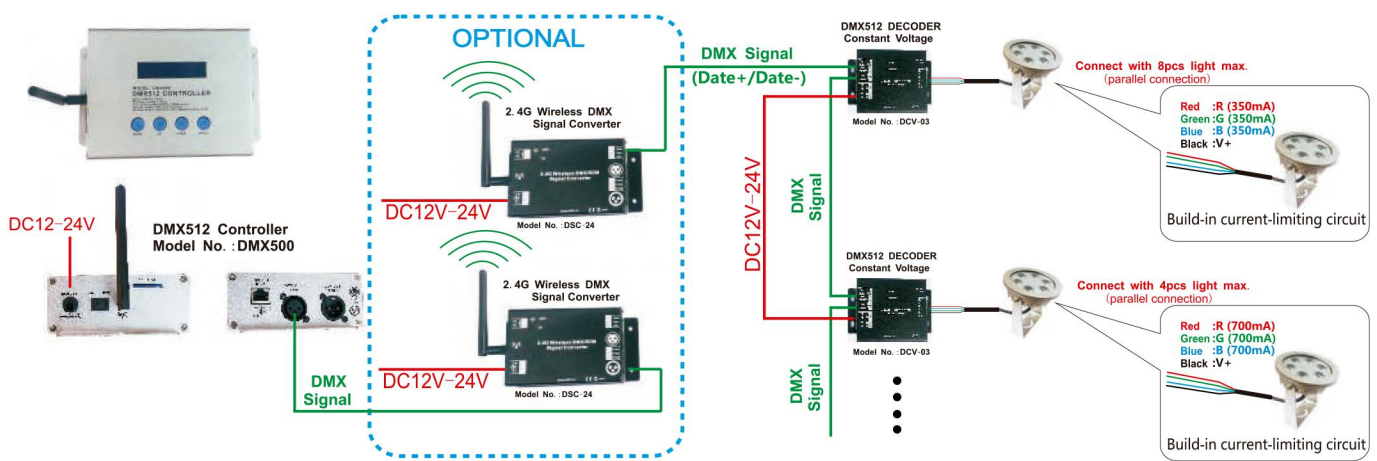

DMX512 Decoder

Item Code: 88609
Model No.: WP-DCV-03

External (3)

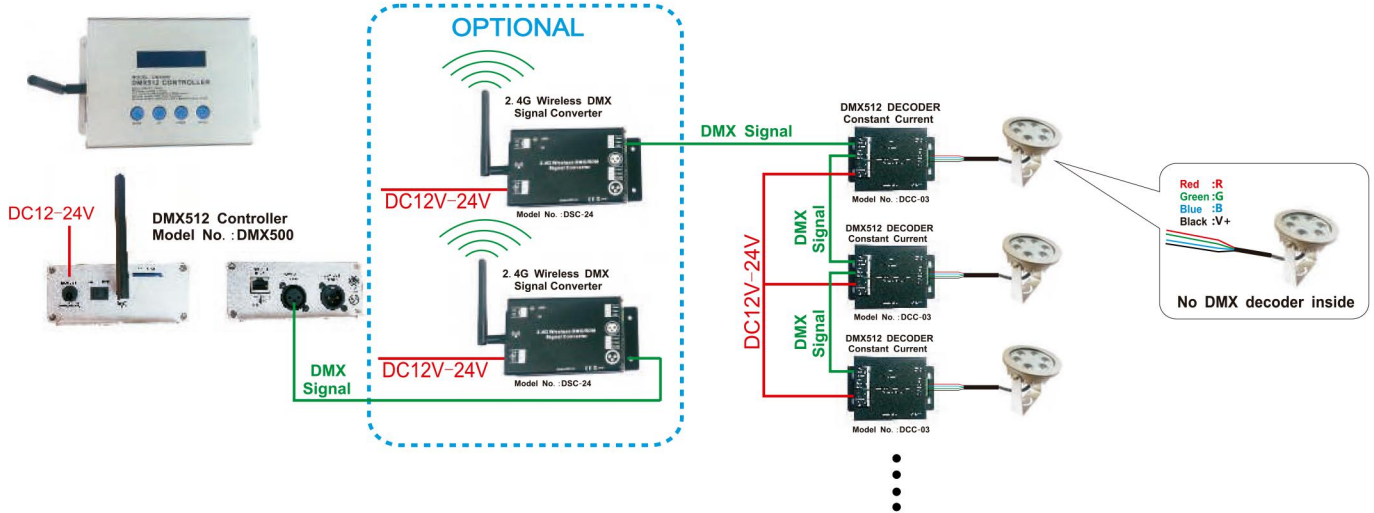

DMX512 Signal Amplifier (4)

